



# Birlea

Suppliers of inspiration

## Assembly Instructions

---

Thank you for  
purchasing a  
Birlea product.

For a chance to win a *Love 2 Shop* voucher simply post a picture of your new product on your preferred social channels tagging Birlea Furniture and using the hashtag **#ShareYourStyle** and **#Birlea**. One winner will be selected at random each month.

To view our full terms and conditions please visit our website. [www.birlea.com](http://www.birlea.com)

---

### Are you happy with your purchase?

**Yes:** That's great, we would love to hear more from you. Please leave us a review on our social media channels or Trustpilot. Your feedback will be greatly appreciated.

**No:** If for any reason there is something missing, indifferent or incorrect with your order, please contact the retailer you purchased the item from. We will work with the retailer to resolve your issue as quickly as possible.



[www.birlea.com](http://www.birlea.com)

## ASSEMBLY INSTRUCTIONS

### PEMBROKE 2 DOOR WARDROBE PINE

**IMPORTANT: READ THESE INSTRUCTIONS CAREFULLY BEFORE ASSEMBLING OR USING YOUR PEMBROKE 2 DOOR WARDROBE PINE.**

**PLEASE KEEP THESE INSTRUCTIONS FOR FUTURE REFERENCE.**

#### **HEALTH & SAFETY:**

DO NOT use this item if any parts are missing, damaged or worn.

DO NOT use this item unless all fixings are secured.

Please keep small parts out of reach of children.

Always use on a level, even surface.

It is recommended that two people handle and assemble the item.

Birlea advise you use the wall straps provided to further enhance the safety of this product.

#### **CARE & MAINTENANCE:**

Assemble in the room of use.

To avoid damages assemble the item on a soft, clean surface

Periodically check all screws & fixings to ensure they are secure.

DO NOT push the item as this will damage the base.

Always lift the item with two people to reposition.

Keep any sharp objects away from the item.

This product is manufactured in pine which is a wood with natural characteristics including knots, grains, clusters or indentations.

On unpacking the item you may notice an odour due to production processes but this will disappear after a period of time.

DO NOT place the item next to a radiator or direct sunlight – this item is susceptible to temperature change.

It is recommended an even room temperature be maintained with no sudden fluctuations.

DO NOT place hot or cold items directly onto the surface of the item as marking will occur





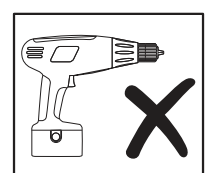
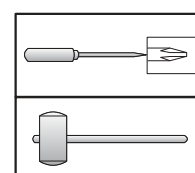
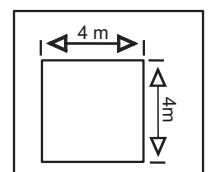
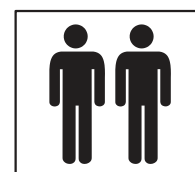
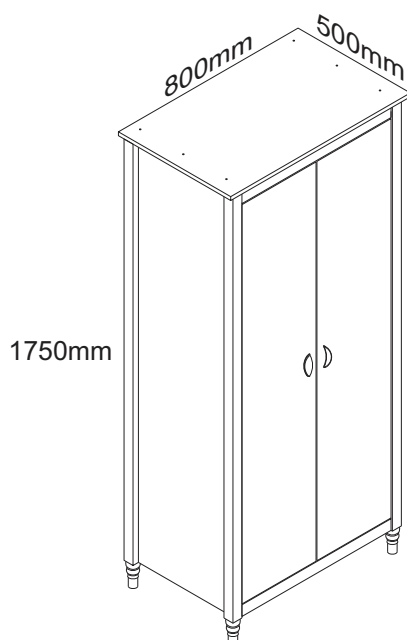

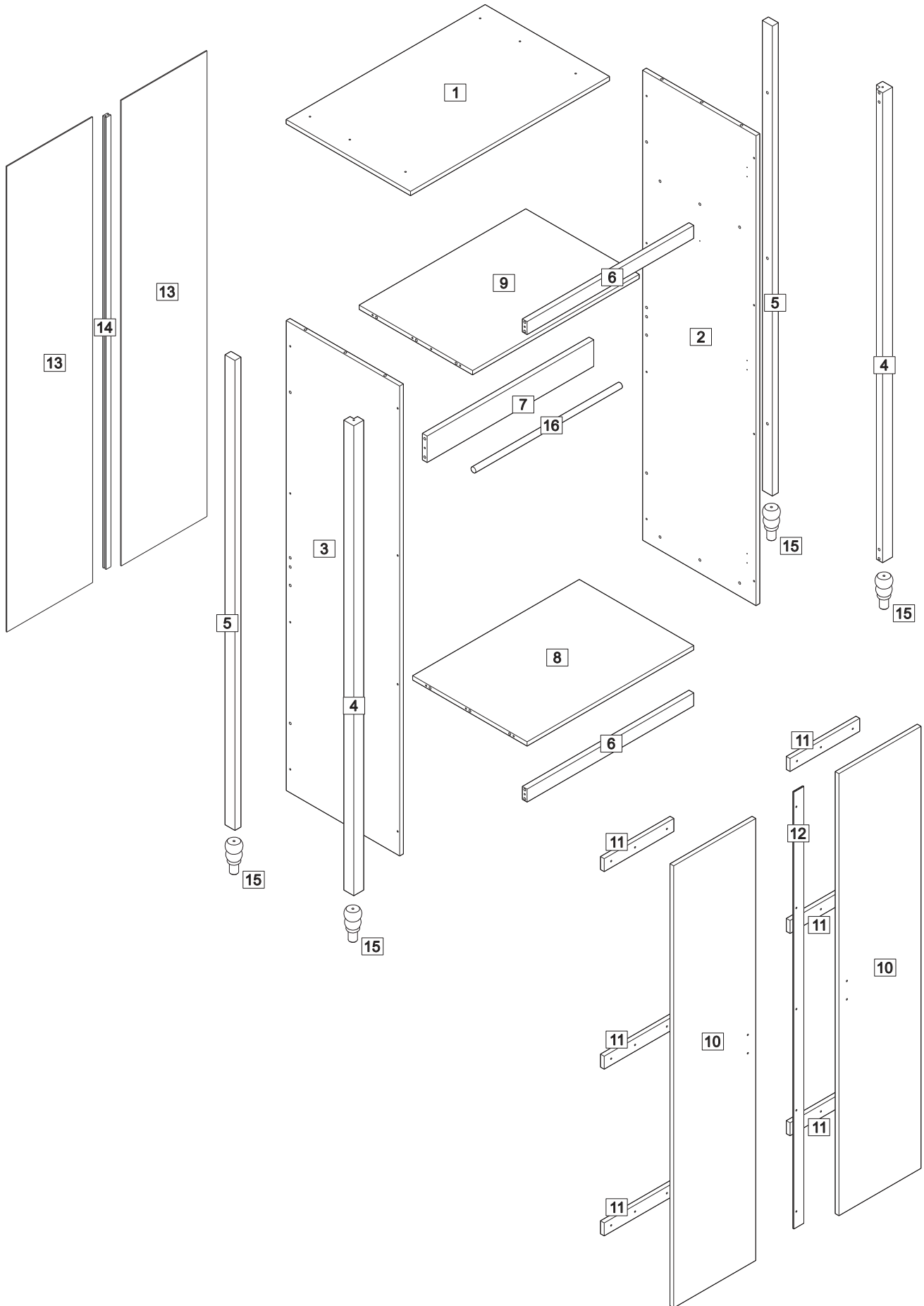









For general cleaning use a duster or damp cloth (almost dry) not wet – do not use soap and water, detergents, aerosol sprays or any polish as use of these materials would invalidate any claims.

DO NOT place the item onto wet or damp flooring as staining may occur to the floor.



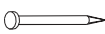

PARTS LIST		
Part	Item	Qty
1	Top Panel	1
2	Right Side	1
3	Left Side	1
4	Front Side Column	2
5	Back Side Column	2
6	Front cross member	1
7	Rear Cross Member	1
8	Base	1
9	Shelf	1
10	Door	2
11	Apply Door	6
12	Stop Door	1
13	Back Background	2
14	H Profile	1
15	Foot	4
16	Hanging Rail	1

HARDWARE LIST		
Part	Item	Qty
<b>A</b>	Wooden dowel 	36
<b>B</b>	14mm Screw 	48
<b>C</b>	25mm Screw 	18
<b>D</b>	30mm Screw 	34
<b>E</b>	35mm Screw 	6
<b>F</b>	18mm Screw 	4
<b>G</b>	60mm superb bar 	4
<b>H</b>	60mm superb bar 	6
<b>I</b>	60mm superb bar 	6
<b>J</b>	Smooth shell pull 	2
<b>K</b>	Smooth shell pull 	2
<b>L</b>	Smooth shell pull 	2
<b>M</b>	Smooth shell pull 	2
<b>N</b>	Smooth shell pull 	2
<b>O</b>	Washer 	2
<b>P</b>	Wall Strap 	1
<b>Q</b>	Tack 	44

\*\* You will need a small mallet and a screwdriver.

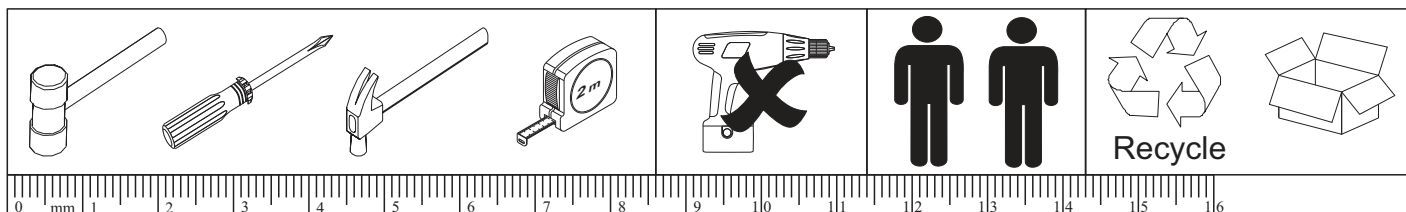

**STEP 1:** Insert the hardware (A) in the parts shown.

Vendor: S000238

**Do NOT use any power tools as this may damage the frame and will invalidate any claim.**

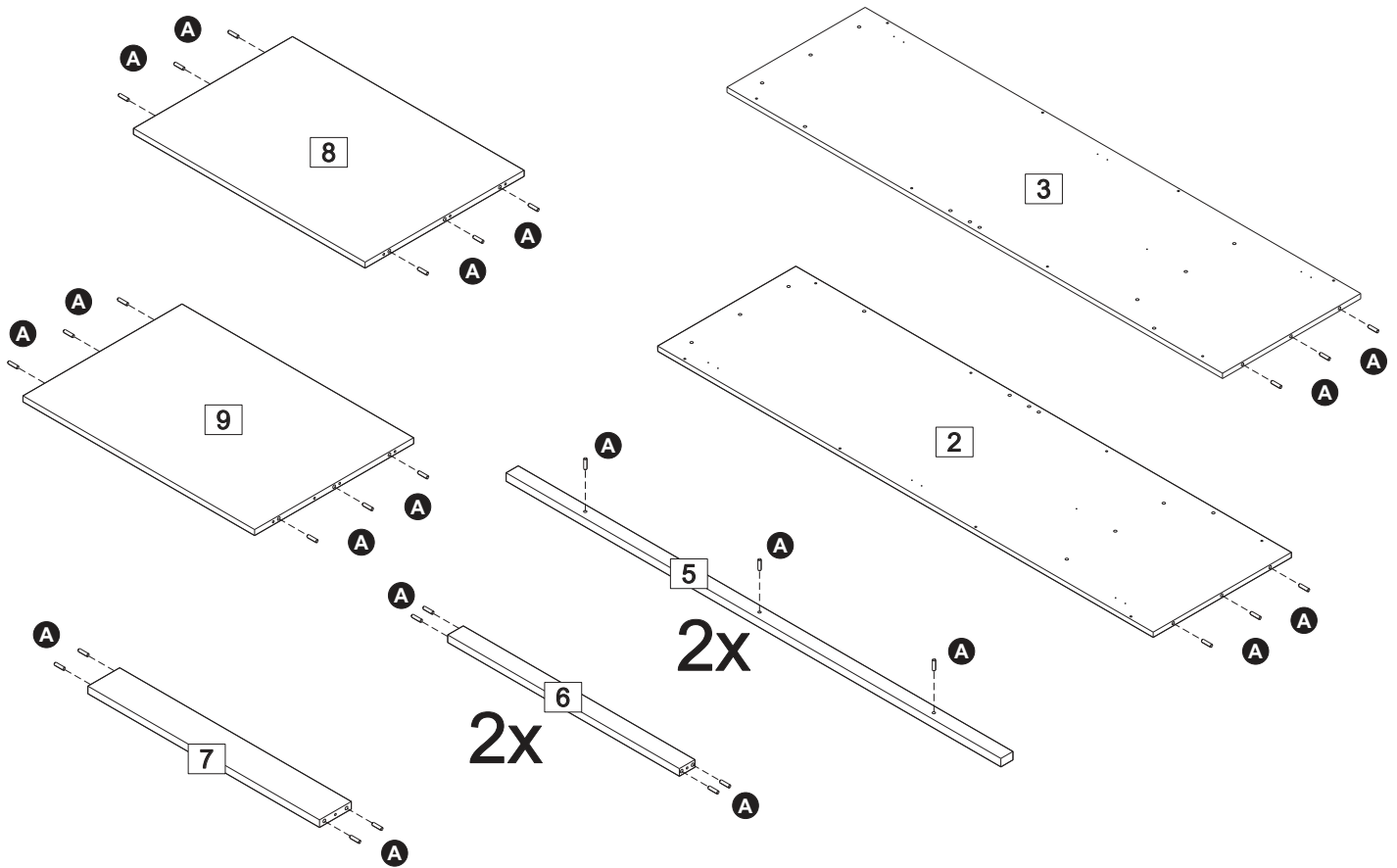

**STEP 2:** Fix the right side (2) and left side (3) into the front side column (4) and back side column (5) using hardware (D).

**Do NOT use any power tools as this may damage the frame and will invalidate any claim.**

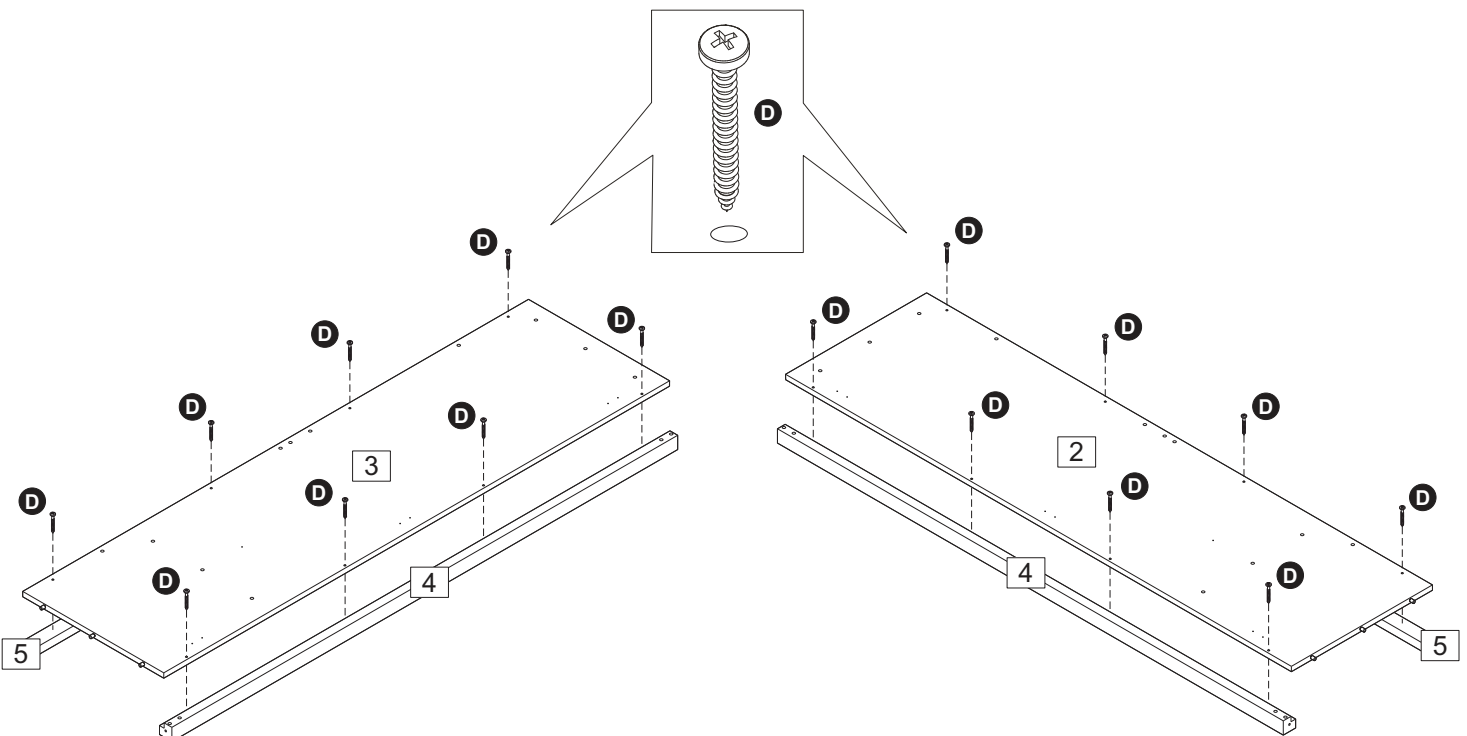

**STEP 3:** Insert the hardware (G) into the foot (15) then insert the feet into the assembled parts (2) and (3).

Vendor: S000238

**Do NOT use any power tools as this may damage the frame and will invalidate any claim.**

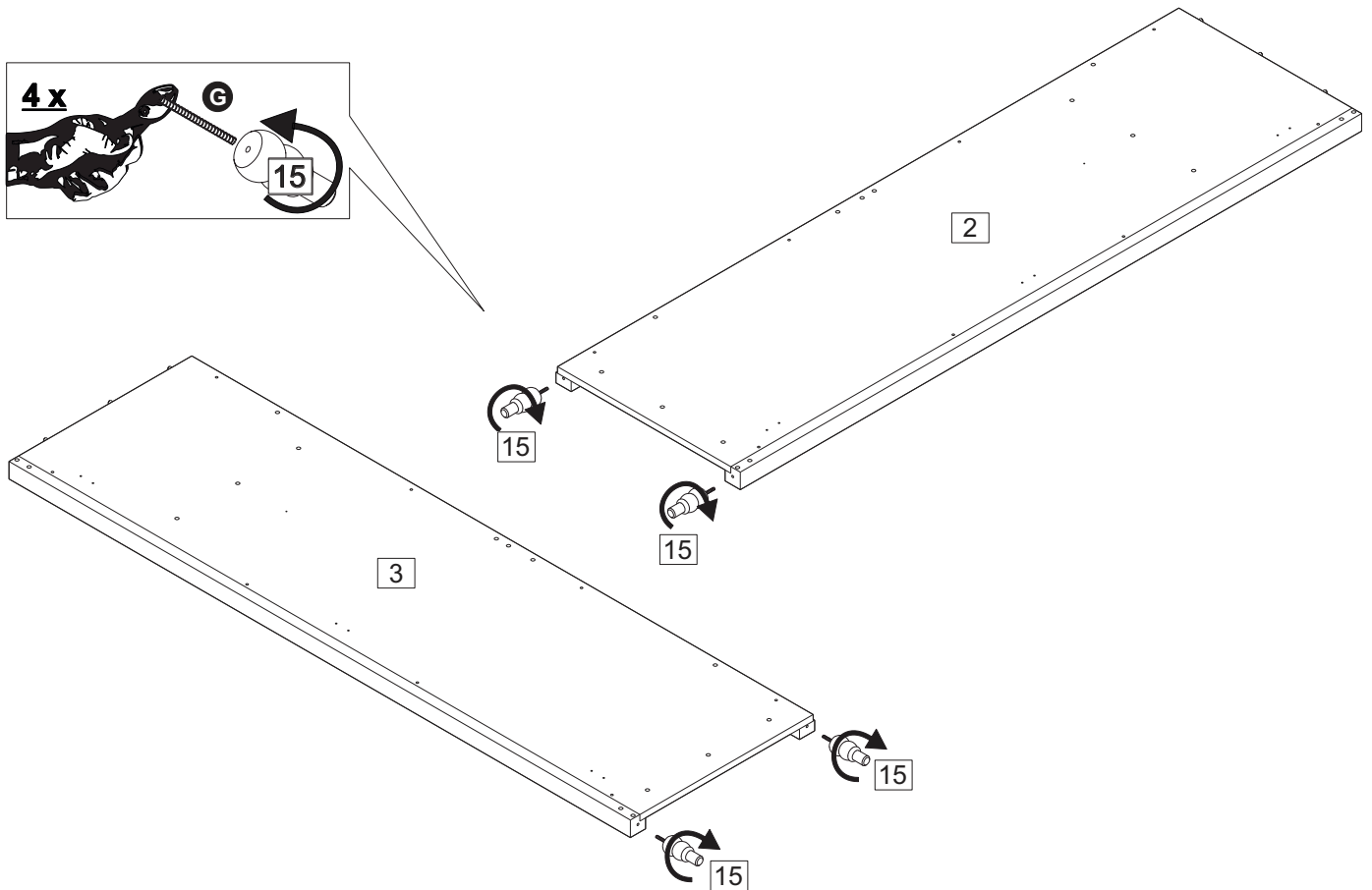

**STEP 4:** Use the hardware (B) to fix the hardware (I) and (N) onto the assembled parts (2) and (3).  
**Do NOT use any power tools as this may damage the frame and will invalidate any claim.**

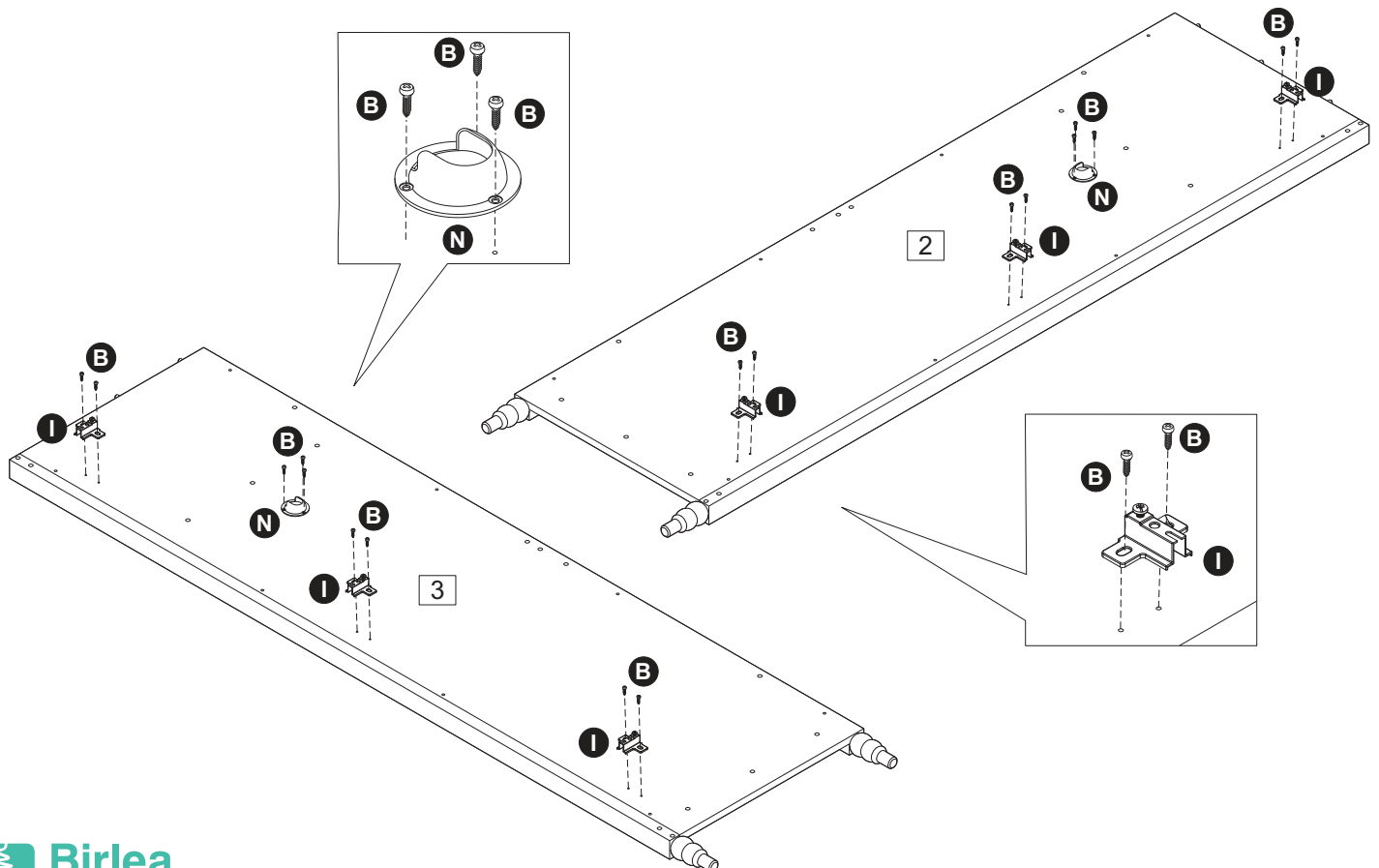

**STEP 5:** Attach the base (8) and shelf (9) to the right side (2) using hardware (D).  
**Do NOT use any power tools as this may damage the frame and will invalidate any claim.**

Vendor: S000238

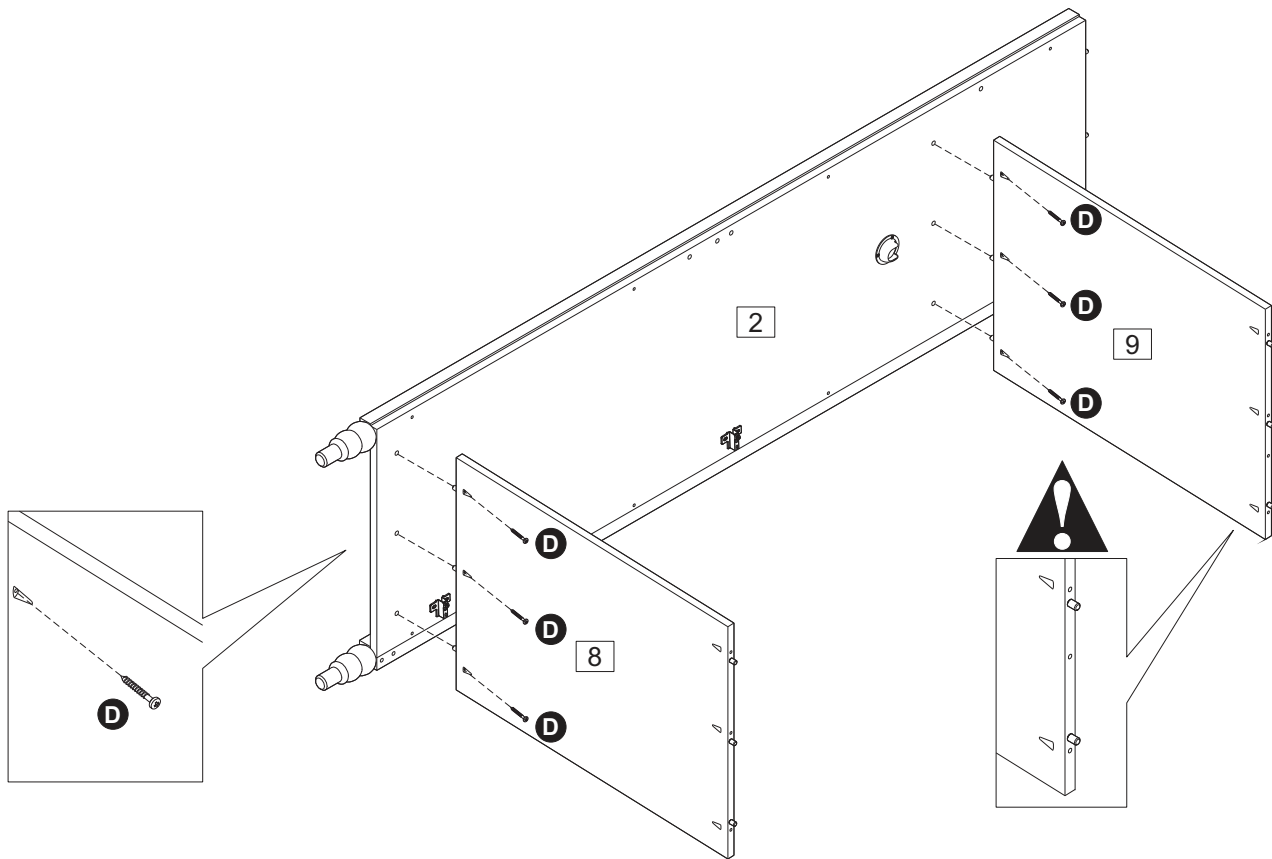

**STEP 6:** Attach the front cross member (6) and the rear cross member (7) to the right side (2) using hardware (D).  
**Do NOT use any power tools as this may damage the frame and will invalidate any claim.**

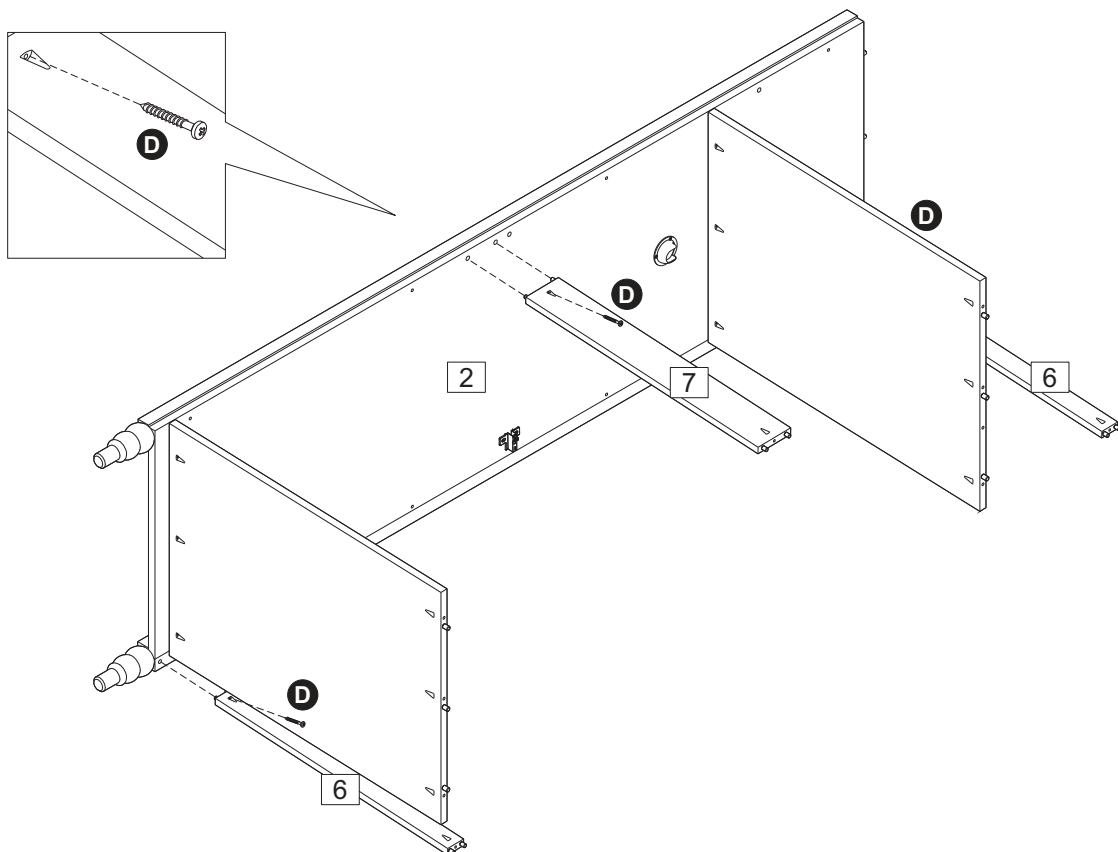

**STEP 7:** Attach the base (8), shelf (9), front cross members (6) and the rear cross member (7) into the assembled left side (3) using hardware (D).  
Vendor: S000238  
Do NOT use any power tools as this may damage the frame and will invalidate any claim.

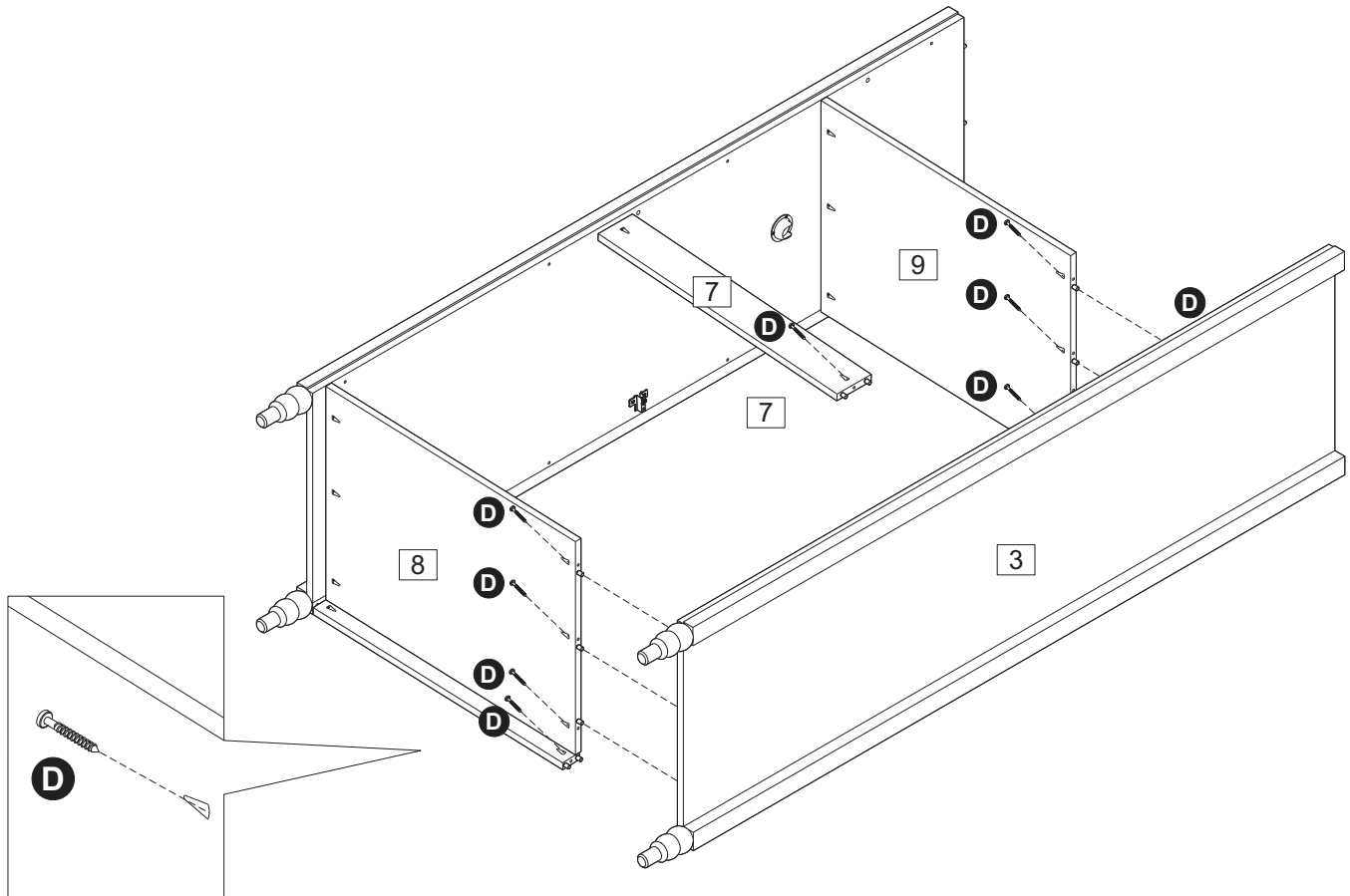

**STEP 8:** Attach the top panel (1) in the assembled frame using hardware (E).  
Do NOT use any power tools as this may damage the frame and will invalidate any claim.

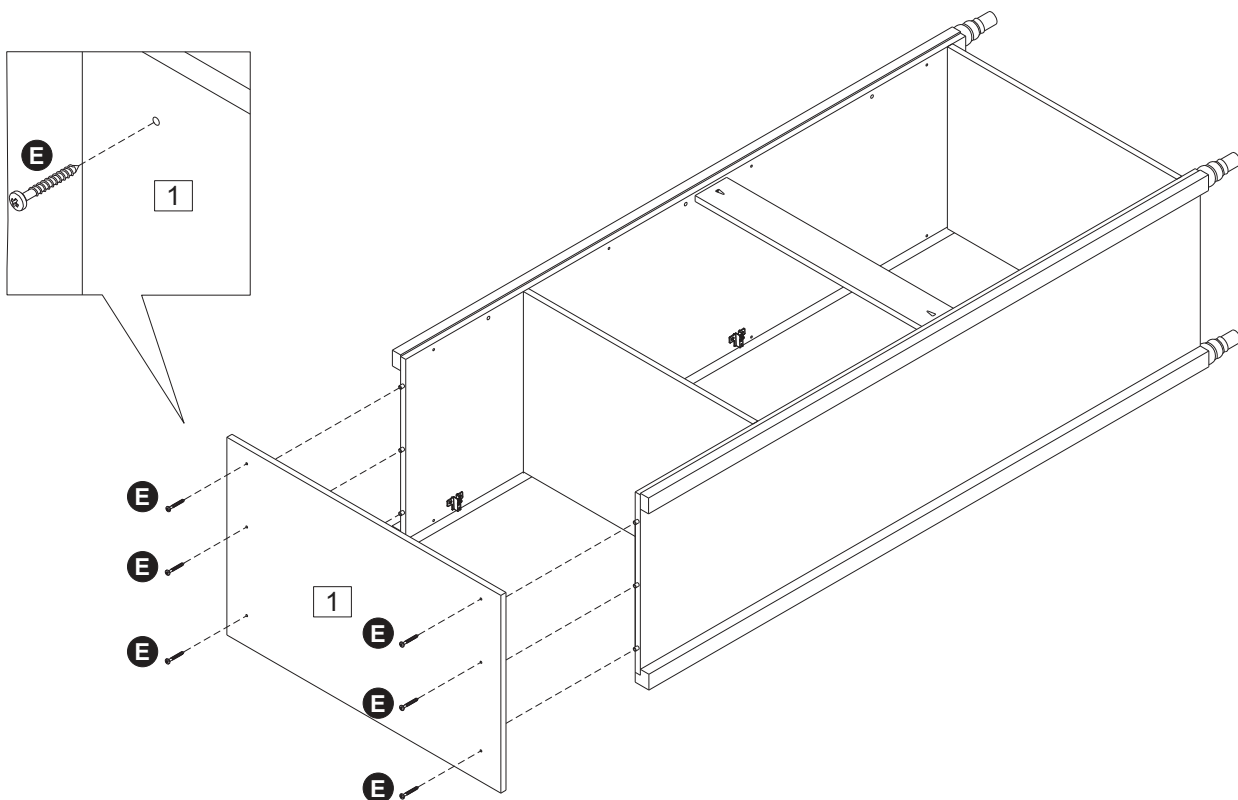



**Step 9:** Use hardware (M) and hardware (B) to fix the front cross member (6) with the base (8) then use hardware (M) and hardware (B) to fix the front cross member (6) to the top panel (1).

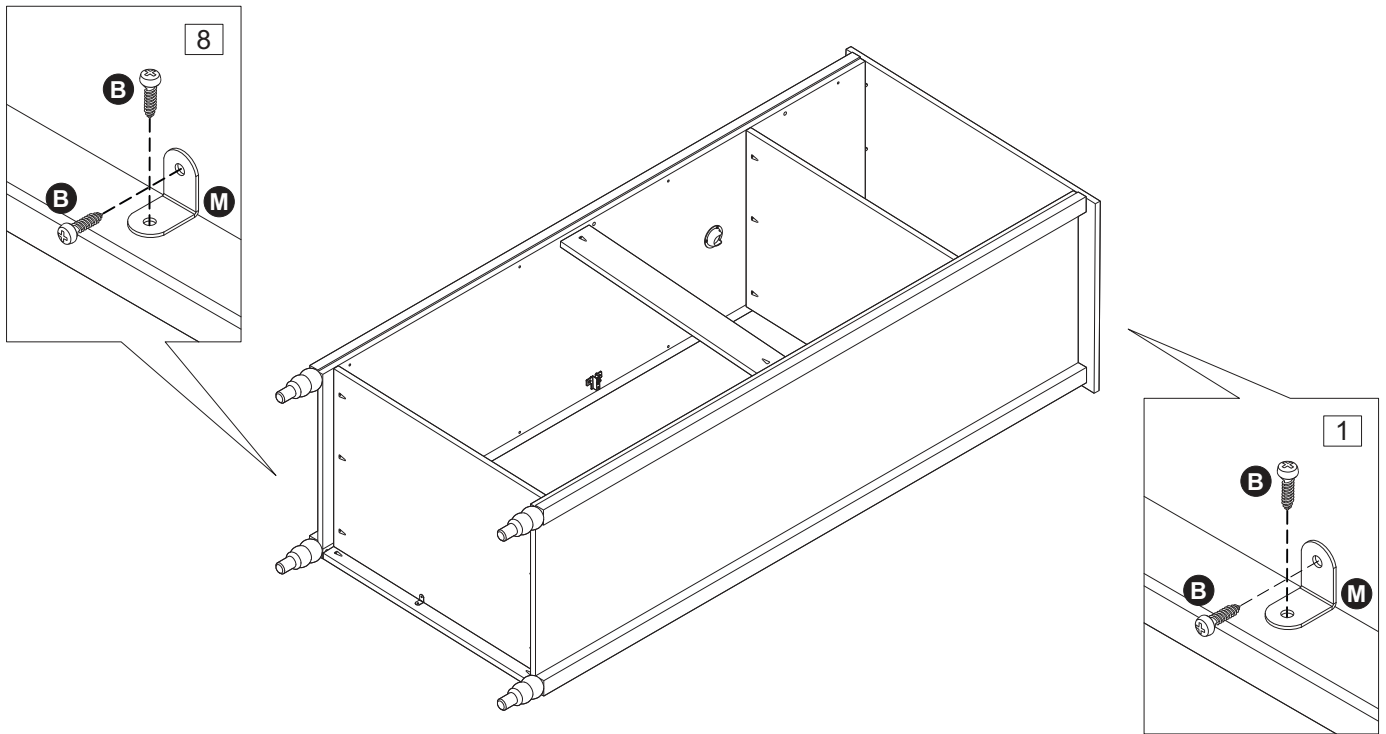

**STEP 10:** Fix the back background (13) with the H profile (14) using hardware (Q).  
**Do NOT use any power tools as this may damage the frame and will invalidate any claim.**

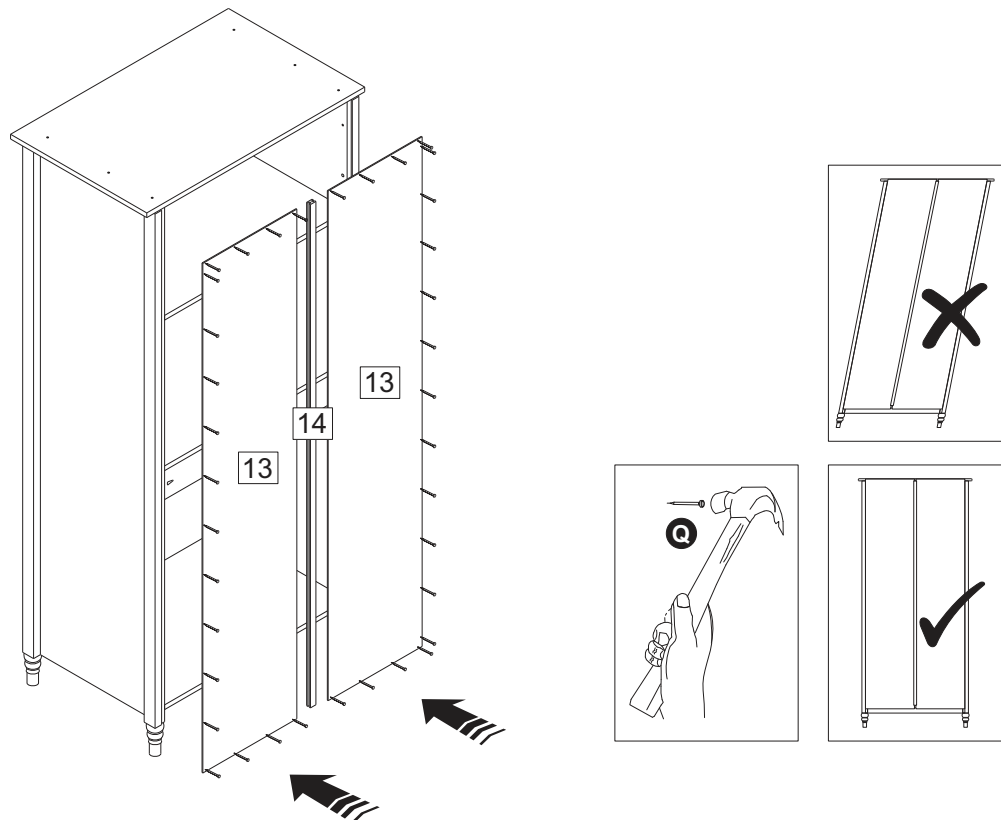

**STEP 11:** Insert the hanging rail (16) using hardware (N).

Vendor: S000238

**Do NOT use any power tools as this may damage the frame and will invalidate any claim.**

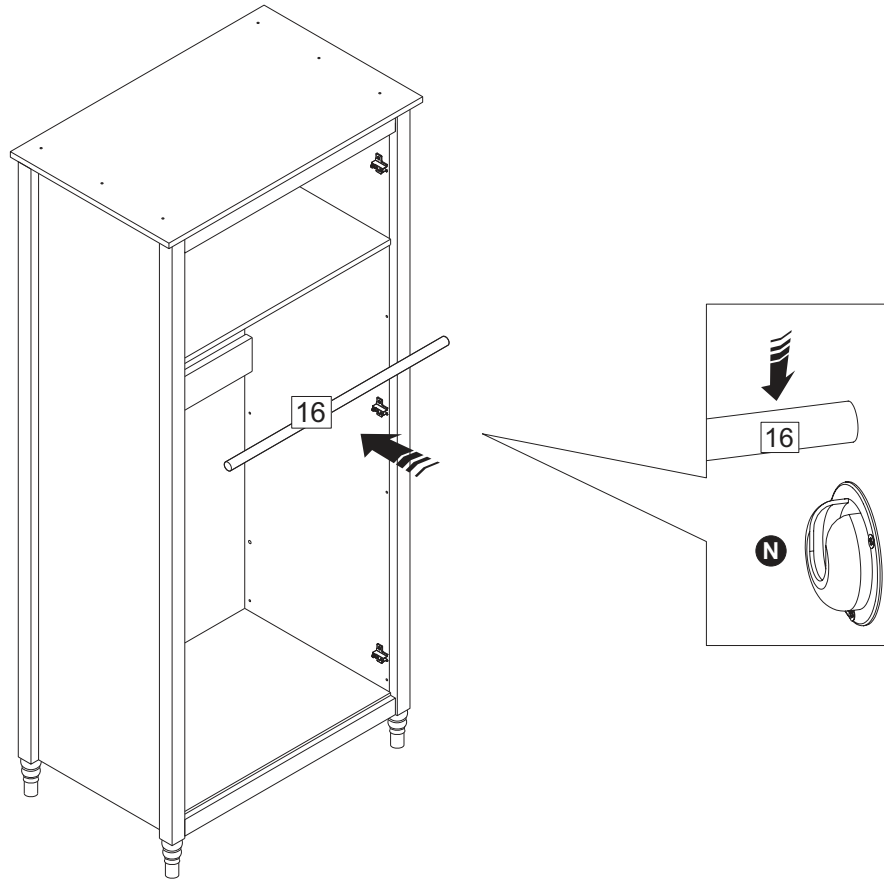

**STEP 12:** Fix the apply door (11) using hardware (D) onto the door (10) then fix the stop door (12) using hardware (B) onto the door (10).

**Do NOT use any power tools as this may damage the frame and will invalidate any claim.**

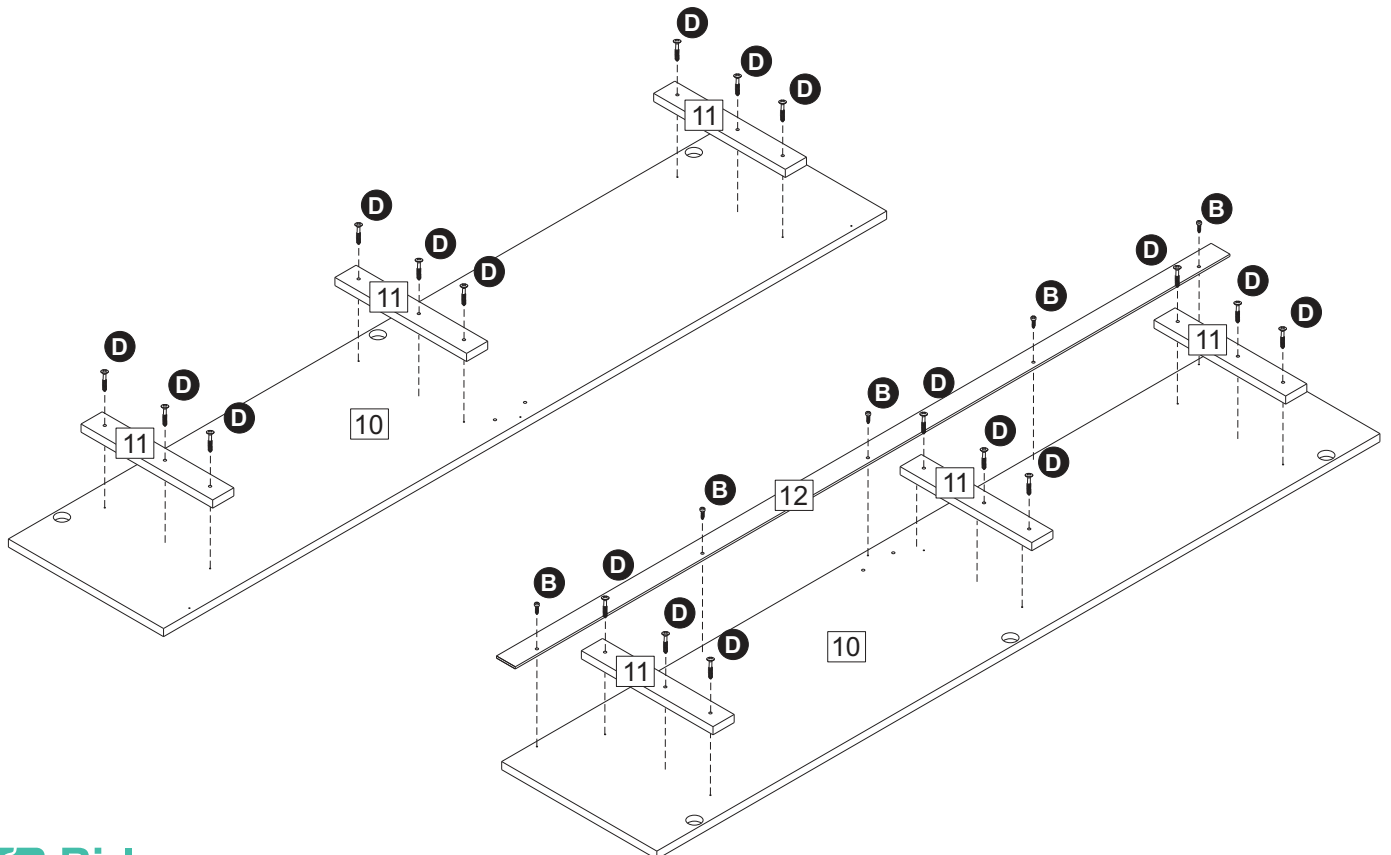

**STEP 13:** Insert the hardware (H) into door (10) using hardware (B).

Vendor: S000238

**Do NOT use any power tools as this may damage the frame and will invalidate any claim.**

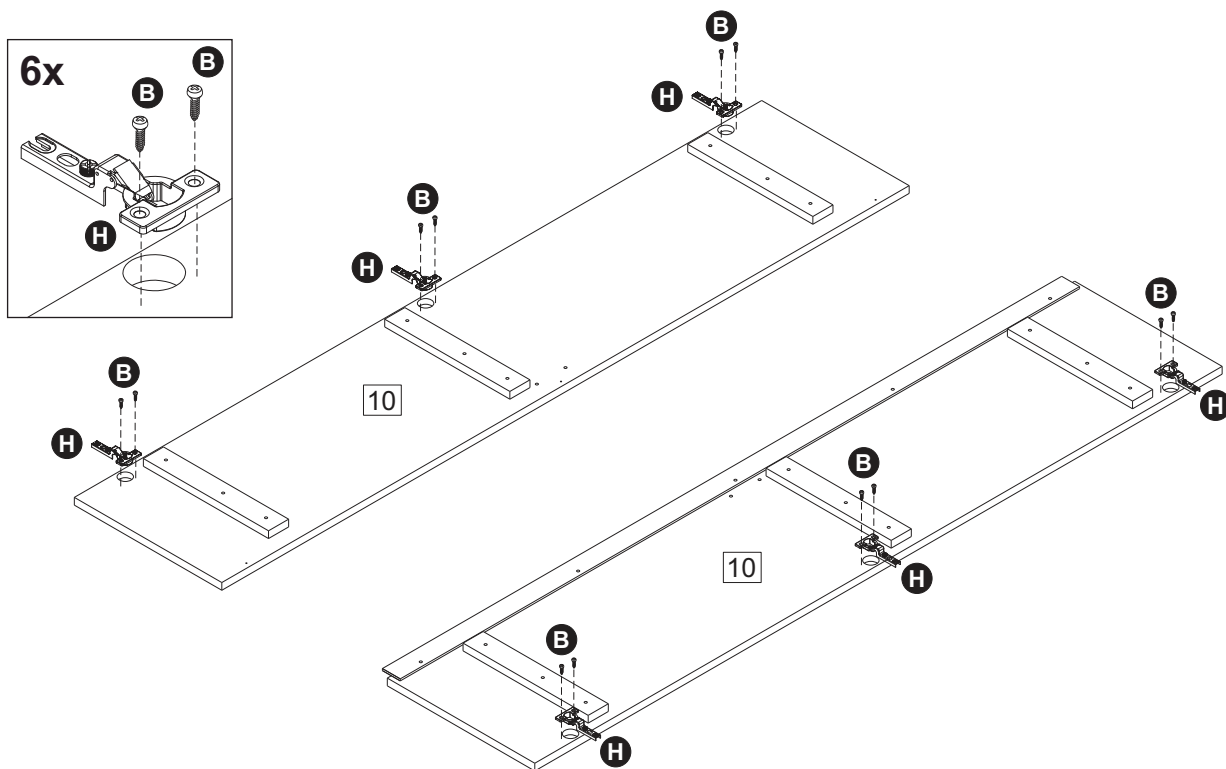

**STEP 14:** Insert hardware (J) using hardware (F) to fix the handle to the door (10) using a screwdriver (not provided).

Fix the door (10) to the right side (2) and the left side (3) using hardware (H).

**Do NOT use any power tools as this may damage the frame and will invalidate any claim.**

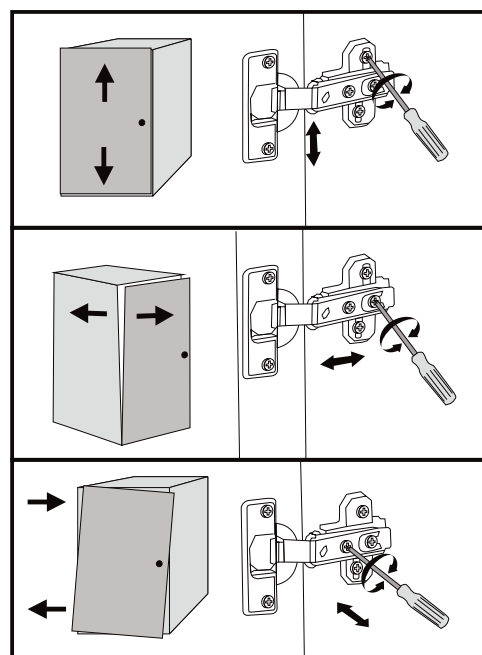
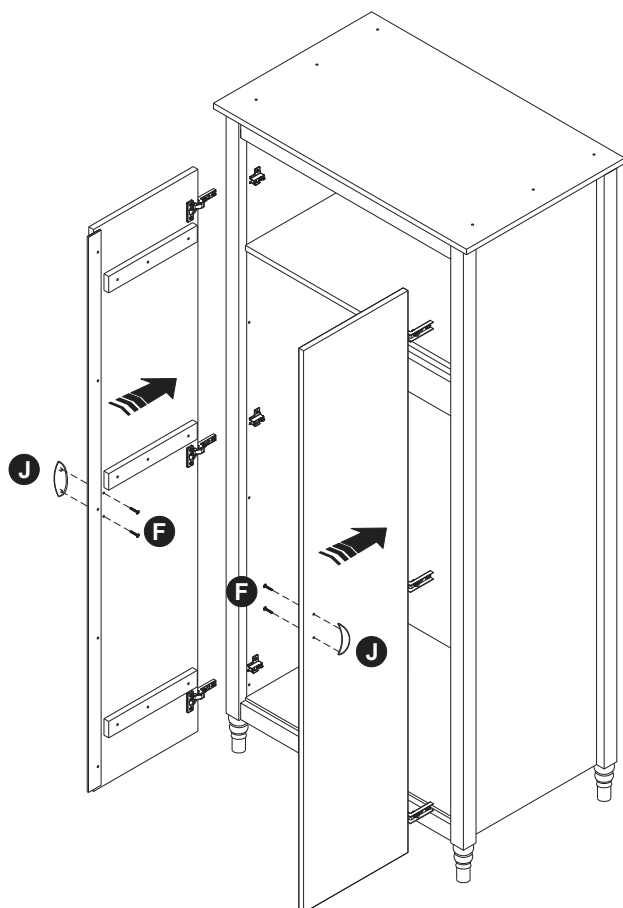

**STEP 15:** Attach hardware (K) to the base (8) and hardware (L) to the door (10) using hardware (B). Vendor: S000238  
**Do NOT use any power tools as this may damage the frame and will invalidate any claim.**

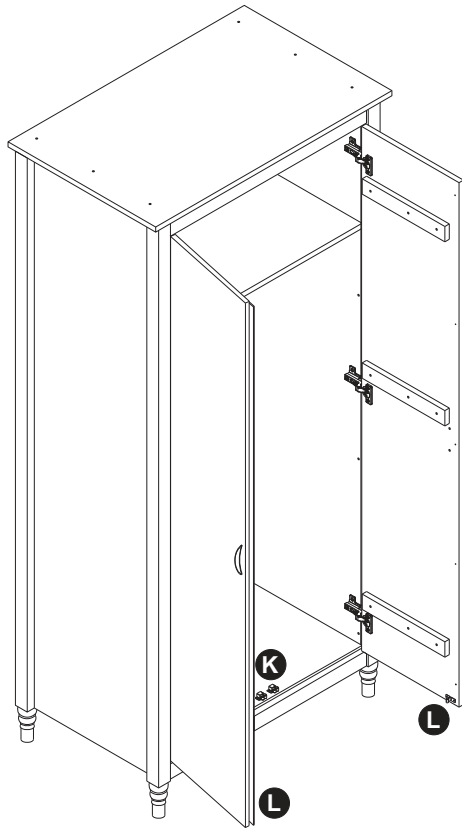

**2x**

**a:**

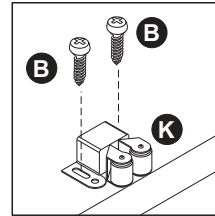

**b:**

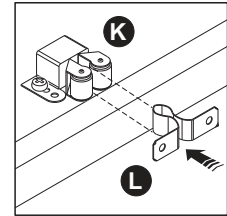

**c:**

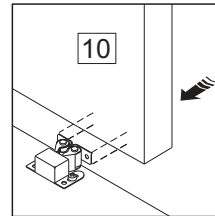

**d:**

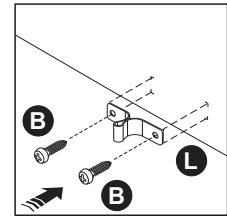

**Step 16:** The furniture needs to be fixed on the wall.

Fix the wall strap (P) to the wall using the washer (O) and a screw (not provided)  
 Attach on the wall using the washer (O) and the 14mm screw (B).

**Wall plug and screw are not supplied to attach the wall strap to the wall.**

**The correct type of fixing must be used for your wall, seek professional advice if in doubt.**

**a:**

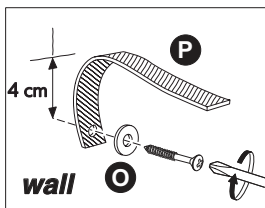

**b:**

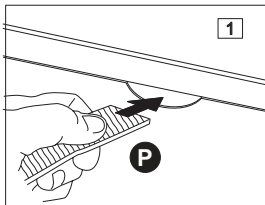

**c:**

